



Mercedesstraße 10
71334 Waiblingen Hegnach

Telefon: 0 71 51 / 5 24 59
Telefax: 0 71 51 / 56 35 24

Spann-Box

- Einsetzbar bei kleiner Kettengeschwindigkeit.
- Schwingungs- und geräuscharmer Lauf durch große Umlenkradien.
- Die Spannkraft kann dem jeweiligen Kettenformat angepasst werden.
- Gleitprofile aus reibungsarmem Kunststoff

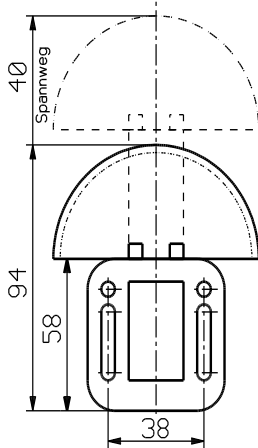
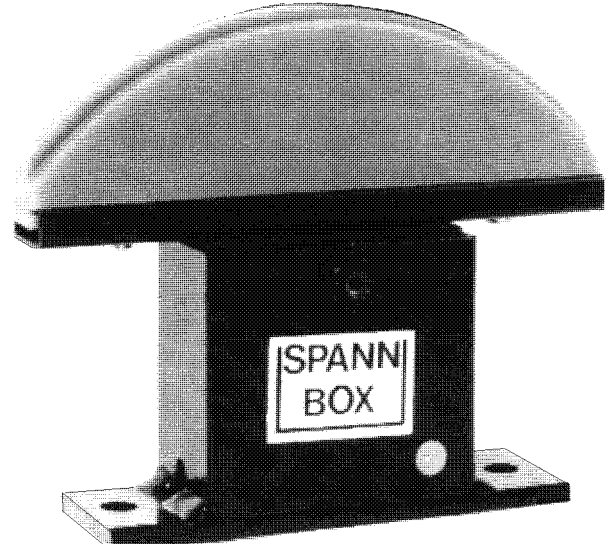

Größe 0 (1-Feder-System, Kunststoffgehäuse)

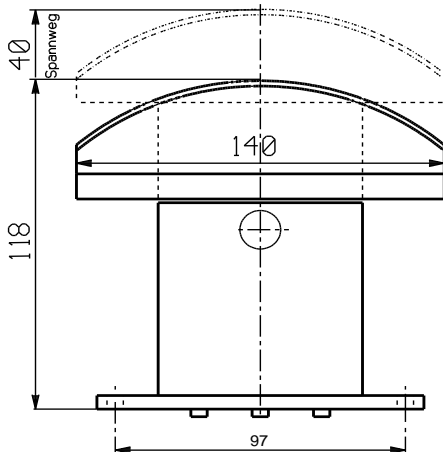

Größe 1 (3-Feder-System, Stahlgehäuse)

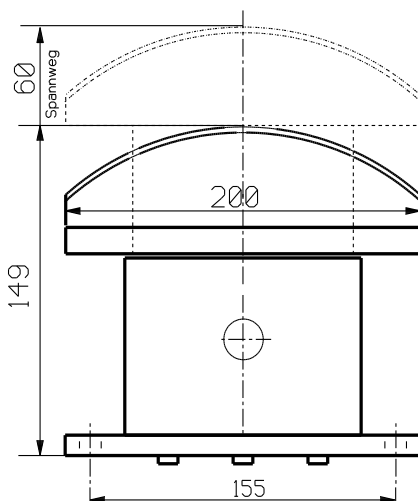

Größe 2 (3-Feder-System, Stahlgehäuse)

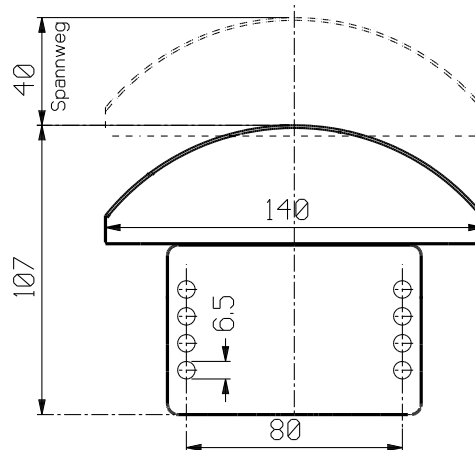

Größe 30 (3-Feder-System, Kunststoff)

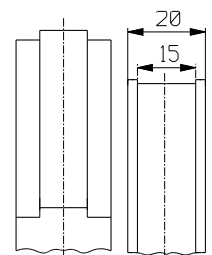

T-Profil U-Profil

Spannweg	Größe 0		Größe 1 u. 30		Größe 2	
	40 mm		40 mm		60 mm	
Kraft in [N]	leicht	schwer	leicht	schwer	leicht	schwer
1 Feder	58-32	132-60	58-32	132-60	148-82	262-118
2 Federn	-	-	116-64	264-120	296-164	524-236
3 Federn	-	-	174-96	396-180	444-246	786-454

Best.nummern: (zusätzl. muß "schwer" oder "leicht" angegeben werden)

	Größe 0	Größe 30	Größe 1	Größe 2
T-Profil für Kette				
08B-1 (1/2"x5/16")	SB0-08B-1	SB30-08B-1	SB1-08B-1	
10B-1 (5/8"x3/8")	SB0-10B-1	SB30-10B-1	SB1-10B-1	
12B-1 (3/4"x7/16")		SB30-12B-1	SB1-12B-1	SB2-12B-1
16B-1 (1"x17mm)		SB30-16B-1	SB1-16B-1	SB2-16B-1
20B-1 (1 1/4"x3/4")			SB1-20B-1	SB2-20B-1
24B-1 (1 1/2"x1")				SB2-24B-1
05B-2 (8mmx1/8")		SB30-05B-2		
06B-2 (3/8"x7/32")	SB0-06B-2	SB30-06B-2	SB1-06B-2	
08B-2 (1/2"x5/16")	SB0-08B-2	SB30-08B-2	SB1-08B-2	SB2-08B-2
10B-2 (5/8"x3/8")		SB30-10B-2	SB1-10B-2	SB2-10B-2
12B-2 (3/4"x7/16")		SB30-12B-2	SB1-12B-2	SB2-12B-2
16B-2 (1"x17mm)			SB1-16B-2	SB2-16B-2
20B-2 (1 1/4"x3/4")				SB2-20B-2
24B-2 (1 1/2"x1")				SB2-24B-2
06B-3 (3/8"x7/32")		SB30-06B-3	SB1-06B-3	
08B-3 (1/2"x5/16")		SB30-08B-3	SB1-08B-3	SB2-08B-3
10B-3 (5/8"x3/8")			SB1-10B-3	SB2-10B-3
12B-3 (3/4"x7/16")			SB1-12B-3	SB2-12B-3
16B-3 (1"x17mm)				SB2-16B-3
20B-3 (1 1/4"x3/4")				SB2-20B-3
U-Profil	SBU-0	SBU-30	SBU-1	